



BAT/50002

Utilizing clean energy efficiently to keep the earth infinitely green

TABLE OF CONTENT

	SAFETY PRECAUTIONS	01
1.1 BEFORE OPERATION		01
1.2 DURING OPERATION		02
	INTRODUCTION TO BAT/50002	02
2.1 KEY FEATURES		03
2.2 INTERFACE INTRODUCTION		04
2.3 SPECIFICATIONS		05
	SAFE HANDLING GUIDE	03
3.1 TOOLS		06
3.2 SAFTY GEARS		06
3.3 INSTALLATION LOCATION		06
	INSTALLATION AND OPERATION	04
4.1 PACKING LIST		07
4.2 ELECTRICAL WIRING CONNECTION		08
4.3 COMMUNICATION CONNECTION		08
4.4 ROUTINE OPERATION		09
4.5 PARALLEL USE OF BATTERIES		11
	OTHERS	05
5.1 TROUBLESHOOTING		13
5.2 EMERGENCY SITUATIONS		14
5.3 CONTACT		15

01 SAFETY PRECAUTION

- It is very important and necessary to read the user manual carefully before installing or using the battery. Failure to follow any of the instructions or warnings in this document can result in electrical shock, serious injury, death, or may damage the battery and the whole system.
- If the batteries are stored for a prolonged time, it is requirement that they are charged every three to six months, and the SOC should be no less than 80%.
- The battery needs to be recharged within 12 hours, after fully discharging.
- All battery terminals must be disconnected before maintenance.
- Do not use cleaning solvents to clean the battery.
- Do not expose the battery to flammable or harsh chemicals or vapors.
- Do not paint any part of the battery; include any internal or external components.
- Do not connect battery with PV solar wiring directly.
- Any foreign object is prohibited to be inserted into any part of the battery.
- Any warranty claims are excluded for direct or indirect damage due to items above.

1.1 BEFORE OPERATION

- After unpacking, please check the battery and packing list first, if the battery is damaged or spare parts are missing, please contact us.
- Before installation, be sure to cut off the external power and make sure the battery is in the turned-off mode.
- Wiring must be correct, do not mix-connect the positive and negative cables, and ensure no short circuit with the external device.
- It is prohibited to connect the battery with AC power directly.
- The embedded BMS in the battery is designed for 48VDC, please DO NOT connect battery in series.
- It is prohibited to connect the battery with different type of battery.
- Please ensure the electrical parameters of battery system are compatible to inverter.
- Keep the battery away from fire or water.

1.2 DURING OPERATION

- If the battery system needs to be moved or repaired, the power must be cut off first and the battery is completely shut down.
- It is prohibited to put the batteries working with faulty or incompatible inverter.
- In case of fire, only dry powder fire extinguisher can be used, liquid fire extinguishers are prohibited.
- Please do not open, repair or disassemble the battery. We do not undertake any consequences or related responsibility due to violation of safety operation or violating of design, production and equipment safety standards.

02 INTRODUCTION TO BAT/50002

BAT/50002 is a high-performance energy storage battery , which is specially designed for T4 level internet data center and residential and industrial solar energy storage.

2.1 KEY FEATURES

- LiFePO4 composition – provides exceptional safety and longevity.
- 3U height, excellent energy density.
- 6,000 cycles.
- Consistent performance over wide temperature range.
- Support 19 inch cabinet, convenient installation.
- Integrated state-of-the-art BMS to manage and monitor battery information including voltage, current and temperature as well as balance cell charging/ discharging rates.
- Multiple communication modes such as CAN / RS485 / RS232, and has multiple independent communication serial ports, which is convenient for connecting different devices.
- Supports up to 15 modules in parallel, each with the ability to act as a master.
- 8 year warranty (please refer to our warranty document).

2.3 INTERFACE INTRODUCTION

This section details the interface functions of the front panel.

Front interface:

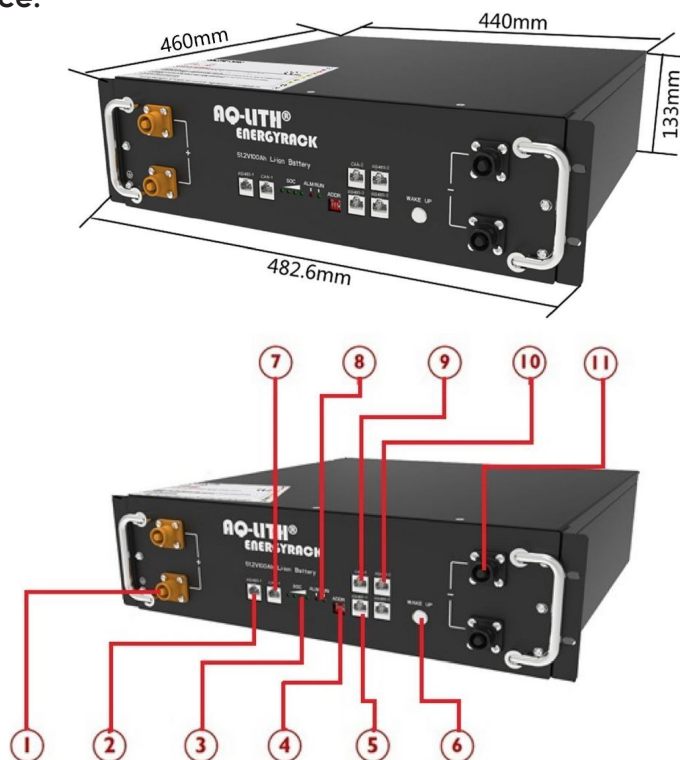

- ①: Positive pole connector*2 — For batteries parallel and power output.
- ②: RS485-1 port — For communication with inverter or EMS.
- ③: SOC Indicators — State of charge indicator, showing the capacity of the battery.
- ④: Dial-up switch — Set the batteries as master or slaves in parallel model.
- ⑤: RS485-3 port — Not used.
- ⑥: Wake up button — To start or shut down the battery.
- ⑦: CAN-1 port — Not used.
- ⑧: Status Indicators — Includes RUN and ALARM indicator.
- ⑨: CAN-2 port — For communication with AQ-TRON & Victron inverter .
- ⑩: RS485-2 port*2 —For communication with Voltronic inverter and inner parallel between batteries .
- ⑪ Negative pole connector*2 — For batteries parallel and power output.

2.4 SPECIFICATIONS

PARAMETERS	BAT/50002
Electrical	
Nominal Voltage (V)	51.2
Nominal Capacity (Ah)	100
Nominal Energy (kWh)	5.12
Operating Voltage Range (V)	43.2~57.6
Standard Charging Current (A)	20
Standard Discharging Current (A)	50
Max. Continuous Output power (kW)	5
Protection	
Over Charge	✓
Over Discharge	✓
Over Current	✓
Reverse Connection	✓
Short Circuit	✓
Temperature	✓
Physical	
Dimensions (WDH, mm)	440×460×133
Weight (kg)	44,2kg
Others	
Communication	RS232/RS485/CAN
Scalability	up to 15
Charging Temperature(°C)	0~45
Discharging Temperature(°C)	-20~50
Certification	to be announced
Compatible Inverters	Victron

03 SAFE HANDLING GUIDE

3.1 TOOLS

The following tools are required to install the battery pack:

- Cross screwdriver.
- Wire cutter.
- RJ45 crimping plier.
- Hydraulic cable plier.
- Multimeter.

Note:

- 1) Use properly insulated tools to prevent accidental electric shock or short circuits.
- 2) If insulated tools are not available, cover the entire exposed metal surfaces of the available tools, except their tips, with electrical tape.

3.2 GEARS

It is recommended to wear the following safety gear when dealing with the battery pack:

- Insulated gloves
- Safety goggles
- Safety shoes

3.3 INSTALLATION LOCATION

Make sure that the installation location meets the following conditions:

- The installation site must be suitable for the size and weight of the battery.
- The battery must be installed on a firm surface to sustain the weight.
- The area is water proof.
- There are no flammable or explosive materials in proximity
- The ambient temperature is within the range from 0°C to 45°C.
- There is minimal dust and dirt in the area.

Note:

- If the ambient temperature is outside the operating range, the battery pack stops operating to protect itself. Frequent exposure to harsh temperatures may deteriorate the performance and life of the battery pack.

04 INSTALLATION AND OPERATION

4.1 PACKING LIST

Thoroughly inspect the packaging upon receipt of goods. If there is any item that is missing or if there is any damage to the external packaging or to the unit itself upon unpacking, please contact us immediately.



Battery

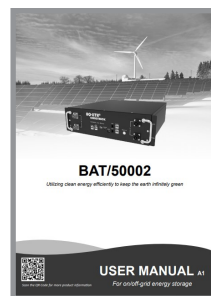

User Manual



Parallel Cable



Netting Cable



Grounding Wire



Screws

Item	Part Name	Description	Unit	Quantity
1	Battery	BAT/50002	pcs	1
2	User Manual	BAT/50002 User Manual	pcs	1
3	Positive pole parallel cable	Orange/0.16m/4AWG	pcs	1
4	Negative pole parallel cable	Black/0.16m/4AWG	pcs	1
5	RJ45 netting cable	Can communication cable for use with VICTRON	pcs	1
6		RS485 communication cable for use with AQTRON	pcs	1
7	Grounding wire	Black/1.5m/10AWG	pcs	1
8	Screws	M8 Cross screw	pcs	8

4.2 ELECTRICAL WIRING CONNECTION

- 1) Before installation, make sure the battery is off (no indicator light is on).
- 2) Before installation, make sure the inverter is off.
- 3) If a DC circuit breaker is installed between the battery and the inverter, make sure the DC circuit breaker is off before the battery is installed.
- 4) Please insert the negative power cable plug into the negative connector on the battery, and gently pull it to make sure it is firmly connected.
- 5) Connect the other end of the negative power cable to the inverter.
- 6) Please insert the positive power cable plug into the positive connector on the battery, and gently pull it to make sure it is firmly connected.
- 7) Connect the other end of the positive power cable to the inverter.

Note:

- 1) Be sure to use the power cable connector dedicated to the manufacture to connect the battery, otherwise it may be dangerous due to poor connection.
- 2) The power cable connecting battery and inverter is optional. Please order according to the actual quantity required.
- 3) Please connect the positive pole after completing the negative pole connection. It is strictly forbidden to insert the positive and negative pole cables into the battery at the same time and then connect the inverter, otherwise it may cause short circuit risk due to overlapping.

4.3 COMMUNICATION CONNECTION

- 1) When the inverter is in lead-acid battery mode, communication connection is not necessary, but we strongly recommend using the inverter model matched with the energyrack and making communication connection, so as to better protect the battery and inverter.
- 2) The battery has two independent RS485 ports for communication with the inverter and EMS. If the inverter only supports can communication, the second port can be connected (please refer to Section 2.3 INTERFACE INTRODUCTION).
- 3) The RJ45 pinout of the communication port is defined as follows.

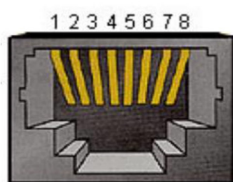

Pin	Definition
1, 8	RS485-B
2, 7	RS485-A
3, 6	GND
4	CAN-H
5	CAN-L

4.4 ROUTINE OPERATION

4.4.1 On/off

- Switch on: When battery is shut down, press the wake up button for 5 seconds. It will be activated when the LED lights flicker from the lowest capacity indicator to the RUN indicator.
- Switch off: When battery is activated, press the wake up button for 5 seconds. It will be shut down when the LED lights flicker from RUN indicator to the lowest capacity indicator.

4.4.2 Sleep mode

- Without RS485/CAN communication, charging/discharging or pressing any buttons, 5 minutes later the battery will enter into sleep mode.
- When the battery is in sleep mode, if any of the following conditions are met, the battery will quit sleep mode and enter into normal operation mode.
 - 1) The inverter charges and discharges battery.
 - 2) Press the wake up button for 1 second, then release the button.
 - 3) Access communication signal (RS485/CAN/RS232).

4.4.3 Power-down mode

- When the lowest cell voltage is lower than the power-down voltage, and the duration reaches the power-down delay time (while meeting the non-charging current at the same time) the battery will enter into the power-down/low-power mode.
- When any of the following conditions are met, the battery will quit power-down mode and enter into normal operation mode:
 - 1) Charging the battery and charging voltage should be higher than 51.2V.
 - 2) Press the wake up button for longer than 2 seconds, then release the button.

4.4.4 Indicators description

- The first four indicators are SOC indicators, representing 0~25%, 25%~50%, 50%~75% and 75%~100% respectively. The next two indicators are used to indicate the status of the battery.
- The indicators can be used to judge whether the battery is in normal state, alarm state or protection state. See the table below for details.

1) SOC status

State		Charging				Discharging			
SOC indicators		LED1	LED2	LED3	LED4	LED1	LED2	LED3	LED4
SOC	0~25%	Flash	OFF	OFF	OFF	ON	OFF	OFF	OFF
	25~50%	ON	Flash	OFF	OFF	ON	ON	OFF	OFF
	50~75%	ON	ON	Flash	OFF	ON	ON	ON	OFF
	75~100%	ON	ON	ON	Flash	ON	ON	ON	ON
RUN Indicator		ON				Flash			

2) Operation status

Mode	Normal / alarm / protection	Alarm indicator	Run indicator
Power Off	Sleep	OFF	OFF
Standby	Normal	OFF	Flash
	Alarm	Flash	Flash
Charging	Normal	OFF	ON
	Alarm	Flash	ON
	Over-charge protection*	OFF	ON
	Temperature, overcurrent, short circuit, and reverse connection protections	ON	OFF
Discharging	Normal	OFF	Flash
	Alarm	Flash	Flash
	Low-voltage protection	OFF	OFF
	Temperature, overcurrent, short circuit, and reverse connection productions	ON	OFF
Failure		ON	OFF

* When over-charge protection occurs, all SOC indicators will also be on.

4.5 PARALLEL USE OF BATTERIES

- When the battery needs to be used in parallel, the maximum connection is 15 units, but we recommend to use 2-12 units according to application.
- The power wiring and communication wiring between batteries must use the special parallel wire
- The batteries used in parallel operation must be the same batch of cases and the voltage difference < 2V.
- BAT/50002 supports master-slave parallel mode. Each battery can be used as a master and others as slaves.
- In parallel operation, the dialer must be used to assign different addresses to each module. The dialer is binary, Please refer to below chart to set up the address.

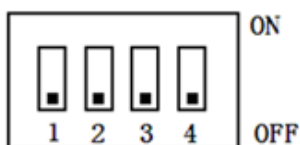

No.	Dial Switch Position				No.	Dial Switch Position				No.	Dial Switch Position			
1# (Master)	ON	OFF	OFF	OFF	6#	OFF	ON	ON	OFF	11#	ON	ON	OFF	ON
2#	OFF	ON	OFF	OFF	7#	ON	ON	ON	OFF	12#	OFF	OFF	ON	ON
3#	ON	ON	OFF	OFF	8#	OFF	OFF	OFF	ON	13#	ON	OFF	ON	ON
4#	OFF	OFF	ON	OFF	9#	ON	OFF	OFF	ON	14#	OFF	ON	ON	ON
5#	ON	OFF	ON	OFF	10#	OFF	ON	OFF	ON	15#	ON	ON	ON	ON

- If the purpose of parallel connection of batteries is to increase the capacity and output power, we recommend the following connection topology.

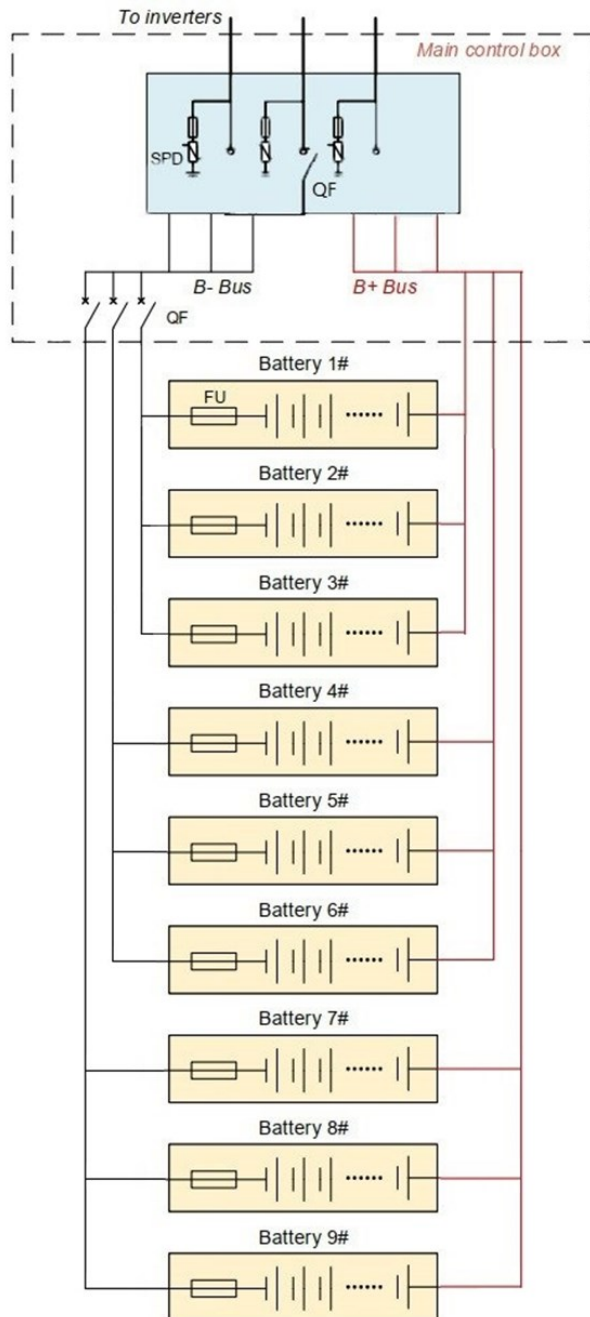

- The main control box specially designed must be used to support this connection mode

05 OTHERS

5.1 TROUBLE SHOOTING

5.1.1 Problem Determination based on:

- Whether the battery can turn on or not;
- If the battery is turned on, check the red light is off, flashing or lighting;
- If the red light is off, check whether the battery can charge/discharge or not.

5.1.2 Preliminary Determination Steps

- Battery cannot turn on
 - 1) Press the "Wake Up" button for 3 seconds.
 - 2) If there is still no LED on, and the output voltage is , please contact us.
- The battery can be turned on but the Alarm indicator is on and the battery cannot charge or discharge. Please check the following:

1) Temperature

Above 45°C or under -0°C: the battery will not charge.

Above 50°C or under -20°C: the battery will not discharge.

Solution: Move battery to a more suitable location to ensure the normal operating temperature range is between 0°C and 45°C.

2) Current

If current is higher than 150A, battery protection will turn on.

Solution: If the current it too high, change the settings of the inverter.

3) High voltage

If charging voltage is above 58.8V, battery protection will turn on.

Solution: If the voltage is too high, change the settings of the inverter.

4) Low voltage

When the battery discharges to 41.6V or less, battery protection will turn on.

Solution: Charge the battery for some time, the Alarm indicator will turn off.

NOTE:

Excluding the four points above, if the fault still cannot be located, turn off the battery and contact us.

- The battery cannot be charged or discharged

Can not charge

- 1) Disconnect the power cables and measure voltage of the inverter.
- 2) If the voltage is 57.6~58.8V, restart the battery, connect the power cables and try again.
- 3) If the battery still cannot be charged, turn off the unit and contact us.

Can not discharge

- 1) Disconnect the power cables and measure the voltage on battery side.
- 2) If the voltage is under 43.2V, charge the battery.
- 3) If the voltage is above 51.2V and still cannot discharge, turn off battery and contact us.

5.2 EMERGENCY SITUATIONS

5.2.1 Leaking Batteries

If the battery pack leaks electrolyte, avoid contact with the leaking liquid or gas. If exposed to the leaking substance, immediately perform the actions below:

- Inhalation: Evacuate the contaminated area, and seek medical attention.
- Contact with eyes: Rinse eyes with flowing water for 15 minutes, and seek medical attention.
- Contact with skin: Wash the affected area thoroughly with soap and water, and seek medical attention.
- Ingestion: Induce vomiting, and seek medical attention.

5.2.2 Fire

- DO NOT USE WATER!!
- Use only dry powder fire extinguisher
- If possible and safe to do so, move the battery pack to a safe area before it catches fire.

5.2.3 Wet Batteries

- If the battery pack is too wet or submerged in water, do not make contact with it, and then contact us for technical support.

5.2.4 Damaged Batteries

- Damaged batteries are dangerous and must be handled with the utmost care. They are not fit for use and may pose a danger to people or property. If the battery pack seems to be damaged, contact us immediately.

5.3 CONTACT

Please contact us if you need technical support.

You may need to provide the following information:

- Item No. of inverter.
- Product series.
- Error code and description.
- Configuration of your system.